



McDonald Submersible Pumps Installation Instructions

INSTALLATION RECORD

Date of Installation _____

Model Number _____ Serial Number _____

Depth of Well (Feet) _____ Depth of Water (Feet) _____

Pump Setting (Feet) _____ Riser Pipe Size _____

Wire Size (From Pump to Control Box) _____

Wire Size (From Control to Power) _____

Motor _____ Amps _____ H.P. _____ Volts _____

Control Box _____ Amps _____ H.P. _____ Volts _____

IMPORTANT

While this pump will handle moderate amounts of sand and abrasive materials, it must be understood that the life of the pump will be shortened. Therefore, do not install this pump in wells which continue to produce sand. The motor has been completely prefilled at the factory and requires no further attention.

1. INSPECT THE EQUIPMENT

Before going on the job, open all packages and check all equipment to be certain everything is included and that no parts have been damaged during shipment. The pump should be checked for free rotation, and the motor and name plate inspected to be sure they are the correct horsepower, voltage and phase.

2. EXTREME TEMPERATURES

The submersible motors on all McDonald units are constructed so that they will not be damaged by exposure to temperatures below freezing. It may be that in some cases the solution in the motor may be frozen in transit to the installation site. If so, the motor should be warmed sufficiently to thaw it before installing in the well.

These motors may be installed in wells where the water temperature is as high as 105°F. For higher temperature installation, consult the factory.

3. WATER SUPPLY

The well casing must be 4" inside diameter or larger to accept the submersible. Do not install the pump closer than 10 feet to bottom of well as warranty applies only when pumping clean well water.

A common method to prevent over-pumping wells is to leave the gate valve (see Testing Pump Before Connecting to Tank), partly closed in the line. Another method is to use liquid level controls tied in with the pump pressure switch. These liquid level control devices provide automatic protection and should be installed according to manufacturers' recommendations.

4. MOTOR PROTECTION

The normal thermal overload relays or heaters used for standard motors will not trip fast enough to protect a submersible motor, and special extra quick-trip protection must be used.

For single-phase motors, this protection is provided by the specially designed and selected protection in the control box.

For three-phase submersible motors, protection must be provided by the thermal overload relays in the magnetic motor starter.

WARRANTY OF THREE-PHASE SUBMERSIBLE MOTORS IS VOID IF PROPER QUICK-TRIP PROTECTORS ARE NOT USED ON ALL THREE LINES.

FOR TWO-WIRE MOTORS: A separate fused disconnect switch with properly sized fuses must be provided between the power supply and the pressure switch.

Always run a separate circuit from the entrance panel to a fused disconnect switch. NEVER connect a submersible to a plug outlet.

Select the correct size cable from the Cable Selection Chart.

5. GROUNDING

WARNING: Failure to ground electrically operated equipment may result in serious electric shock. Refer to local code requirements.

A. Y. McDonald Mfg. Co. provides submersible pumps with ground wires. This ground wire has green insulation (for color coding). Some two and three wire pumps with ground have the ground-wire as part of the lead assembly, and green/ground wire should be attached to the drop-cable, ground wire similar to the power-wire splice connections.

For two-wire and three-wire pumps without the ground wire in the lead assembly, the green/ground wire should be attached to the most convenient motor stud. With the appropriate length of insulation removed, make a complete loop which fits securely around the motor stud and fasten firmly in place with the first jam nut. Then, lock the assembly in place by tightening the second jam nut against the first jam nut. If stranded ground wire is used in-lieu-of the McDonald-supplied solid copper wire, a ring terminal must be crimped on the wire before attachment to the two-wire motor stud.

6. NUMBER OF STARTS

An excessive number of starts will lead to difficulties with pump motors and their associated controls. For maximum pump-motor life and minimum troubles, installations should be sized so that:

Motors of less than 1 H.P. and larger should not be started more than 300 times in a 24-hour period; 1 H.P. and larger should not be started more than 100 times in 24 hours; three-phase motors should not be subjected to more than 300 starts per day.



WARNING: It is unlawful in CALIFORNIA & VERMONT (effective 1/1/2010); MARYLAND (effective 1/1/2012); LOUISIANA (effective 1/1/2013) and the UNITED STATES OF AMERICA (effective 1/4/2014) to use any product in the installation or repair of any public water system or any plumbing in a facility or system that provides water for human consumption if the wetted surface area of the product has a weighted average lead content greater than 0.25%. This prohibition does not extend to service saddles used in California, Louisiana or under USA Public Law 111-380.

7. DIRECTION ROTATION - THREE PHASE ONLY

All McDonald submersible pumps rotate in a counter-clockwise direction (looking into the discharge outlet). Three-phase motors will operate in reverse rotation if improperly connected to the power supply or magnetic starter.

A three-phase pump motor unit running backwards will develop about 50% of its rated output.

To check rotation, momentarily touch the three motor leads to the magnetic starter before installation. The motor should "kick" in a clockwise direction.

Three-phase motors may be reversed by interchanging any two of the three motor leads at the magnetic starter.

8. DROP PIPE

NOTE: Do not use thread sealant on pumps with plastic threads. Always use thread sealant on metallic pipe threads.

Galvanized pipe is recommended for suspending metallic fitted submersible pumps into the well. However, if plastic fitted pumps and plastic pipe are used, a safety cable should be used to prevent loss of pump if pipe should break. Also torque arrestors should be considered to prevent cable from being damaged from the starting and stopping of the pump. The cable should also be taped to the drop pipe with plastic tape at 5 or 10-foot intervals.

Care should be taken when the first length of pipe is attached to the pump. A short piece of pipe should be used, as the weight as leverage of a full length could damage the pump when the assembly is raised.

Schedule 40 galvanized pipe is suitable for settings to 600 feet. For deeper settings, use Schedule 40 pipe for the bottom 600 feet and Schedule 80 for the remainder.

Take great care to keep pipes clean and free from pebbles, scale and thread chips. Make sound, air tight connections at all fittings.

9. INSTALLING PUMP IN WELL

DO NOT LIFT THE PUMP/MOTOR SET BY THE MOTOR LEADS AND NEVER RUN THE PUMP DRY OUT OF WATER AS SUBMERSIBLE CAN BE DAMAGED. If a barrel is available, give the pump a one minute running test before installation. Check well depth before installing, so that the pump will be no nearer than 10 to 20 feet from the bottom of the well. Submerge pump 10 to 20 feet below "drawn down" water level.

9A. A check valve is recommended for each 200 feet of drop pipe, and a relief valve is recommended for every submersible installation.

21000 / 23000 Series pumps are provided with built-in check valves. The J, V, K, L, P, and M Series, 5-25 GPM check valve is designed so that it may be removed. To remove the check valve, use needle nose pliers to grip the poppet tab and unscrew counter clockwise.

22000 Series pumps, depending on the model, may or may not have a check valve that may be removed.

24000/ 26000 Series pumps use a wafer check valve that cannot be removed.

IMPORTANT: If the internal check valve is removed, it is recommended that a check valve be installed in the discharge line within 25 feet of the pump and below the drawdown level of the water supply.

10. TESTING PUMP BEFORE CONNECTING TO TANK

Before starting the submersible the first time, a gate valve should be installed in the line and the line so arranged that the water can be run to waste. This will prevent dirty water from entering the pressure tank and piping system.

Close the gate valve to about 80% shut and start the pump. The partly closed gate valve will hold the pump flow back and prevent "surging" of the well.

As the water clears up, open the valve more and repeat the operation until the water flows clear and clean.

Never stop pump if sand flows with water, as the sand will lock up the pump impellers and pump cannot be started again.

If sand does not clear up after one or two hours pumping, the pump should be pulled and well cleaned by a well driller.

11. FINAL OPERATION CHECK

Secure all piping to pressure tank and cycle the system to be certain that all controls function correctly.

Check out the air pumping equipment and operation of the air volume control on the pressure tank.

If used with a "float-type" pressure tank, or bladder tank, precharge the tank with air to about 2 PSIG lower than the switch-on setting. e.g. 28 pounds on a 30-50 # switch setting.

LIGHTNING PROTECTOR

SINGLE-PHASE Terminal Board of Control Box

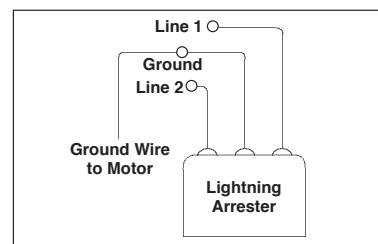

Franklin Electric Super Stainless Submersible Motors manufactured after July, 1972 have built-in lightning protection. No lightning arresters are required.

THREE-PHASE Magnetic Starter

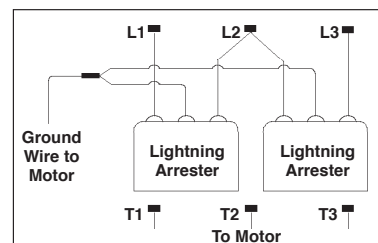

HOW TO IDENTIFY CABLES WHEN COLOR CODE IS LOST (For Single-Phase Units only)

1. Disconnect all three drop cables from the control box. For temporary identification, tie tags to them and give each a number - 1, 2, 3.
2. With an ohmmeter, measure the following three values of "unknown" ohms. Then match the "unknown" item on the left with the "known" item on the right to determine the color of cables 1, 2, 3.

"UNKNOWN"		"KNOWN"	
Cable 1 to cable 2	(_____ ohms)	Lowest -	Black to yellow
Cable 1 to cable 3	(_____ ohms)	Intermed. -	Red to yellow
Cable 2 to cable 3	(_____ ohms)	Highest -	Black to red

3. Note that "yellow" cable is used to obtain lowest and intermediate readings and that "red" cable is used to obtain highest and intermediate readings.

EXAMPLE

Suppose that the ohm readings were:

- 1 to 2 measures 6 ohms (highest)
- 1 to 3 measures 4 ohms (intermediate)
- 2 to 3 measures 2 ohms (lowest)

The actual ohm values are not important. What is important is which reading is highest, intermediate and lowest. This method will work regardless of the actual value of the ohm readings.

Cable 3 was used to obtain the intermediate and lowest ohm reading. This is the yellow cable.

Cable 1 is the cable used to obtain the intermediate and highest ohm readings. This is the red cable.

ATTENTION! Important information for installers of this equipment!

This equipment is intended for installation by technically qualified personnel. Failure to install it in compliance with national and local electrical codes, and with Franklin Electric recommendations, may result in electrical shock or fire hazard, unsatisfactory performance, and equipment failure. Franklin installation information is available from pump manufacturers and distributors, and directly from Franklin Electric. Call Franklin toll free 800-348-2420 for information. **Retain this information sheet with the equipment for future reference.**

WARNING - Serious or fatal electrical shock may result from failure to connect the motor, control enclosures, metal plumbing, and all other metal near the motor or cable, to the power supply ground terminal using wire no smaller than motor cable wires. To reduce risk of electrical shock, disconnect power before working on or around the water system. Do not use motor in swimming areas.

TABLE A - CABLE SELECTION

SINGLE PHASE MOTOR MAXIMUM CABLE LENGTH (Motor to Service Entrance) (2)															
Motor Rating			60°C Insulation - AWG Copper Wire Size												
VOLTS	HP	KW	14	12	10	8	6	4	3	2	1	0	00	000	0000
115	1/2	.37	100	160	250	390	620	960	1190	1780	2160	2630	3140	3770	
230	1/2	.37	400	650	1020	1610	2510	3880	4810	5880	7170	8720			
	3/4	.55	300	480	760	1200	1870	2890	3580	4370	5330	6470	7870		
	1	.75	250	400	630	990	1540	2380	2960	3610	4410	5360	6520		
	1 1/2	1.1	190	310	480	770	1200	1870	2320	2850	3500	4280	5240		
	2	1.5	150	250	390	620	970	1530	1910	2360	2930	3620	4480		
	3	2.2	120	190	300	470	750	1190	1490	1850	2320	2890	3610		
	5	3.7			180	280	450	710	890	1110	1390	1740	2170	2680	

THREE PHASE MOTOR MAXIMUM CABLE LENGTH (Motor to Service Entrance) (2)															
Motor Rating			60°C Insulation - AWG Copper Wire Size												
VOLTS	HP	KW	14	12	10	8	6	4	3	2	1	0	00	000	0000
200V 60 Hz Three-Phase 3 - Lead	1 1/2	1.1	310	500	790	1260	1960	3050	3780						
	2	1.5	240	390	610	970	1520	2360	2940	3610	4430	5420			
	3	2.2	180	290	470	740	1160	1810	2250	2760	3390	4130			
	5	3.7	110	170	280	440	690	1080	1350	1160	2040	2490	3050	3670	4440
	7.5	5.5			200	310	490	770	960	1180	1450	1770	2170	2600	3150
230V 60 Hz Three-Phase 3 - Lead	1 1/2	1.1	420	670	1060	1670	2610	4050	5030	6160	7530	9170			
	2	1.5	320	510	810	1280	2010	3130	3890	4770	5860	7170	8780		
	3	2.2	240	390	620	990	1540	2400	2980	3660	4480	5470	6690	8020	9680
	5	3.7	140	230	370	590	920	1430	1790	2190	2690	3290	4030	4850	5870
460V 60 Hz Three-Phase 3 - Lead	1 1/2	1.1	1700	2710	4270	6730									
	2	1.5	1300	2070	3270	5150	8050								
	3	2.2	1000	1600	2520	3970	6200								
	5	3.7	590	950	1500	2360	3700	5750							
	7.5	5.5	420	680	1070	1690	2640	4100	5100	6260	7680				

CAUTION: Use of wire size smaller than listed will void warranty.

FOOTNOTES:

- If aluminum conductor is used, multiply lengths by 0.5. Maximum allowable length of aluminum is considerably shorter than copper wire of same size.
- The portion of the total cable which is between the service entrance and a 3Ø motor starter should not exceed 25% of the total maximum to assure reliable starter operation. Single phase control boxes may be connected at any point of the total cable length.

TABLE B - ELECTRICAL INFORMATION

MOTOR		SINGLE PHASE						THREE PHASE					THREE PHASE							
		H.P.		2 Wire			3 Wire													
				1/2	1/2	3/4	1	1 1/2	2	3	5	1 1/2	2	3	5	7 1/2	1 1/2	2	3	5
VOLTAGE		115	230	230	230	230	230	230	230	230	230	230	230	230	230	460	460	460	460	460
Standard Fuse Size (Amps)		30	15	20	25	35	30	45	70	15	25	30	45	70	8	11	15	25	35	
Dual Element Fuse Size		15	8	10	11	15	15	20	30	8	10	12	20	30	4	5	6	10	15	
Minimum Voltage (volts)		105	210	210	210	210	210	210	210				210						414	
Maximum Voltage (volts)		125	250	250	250	250	250	250	250				250						506	
Maximum Current (amps)-Motor Running Under		12	6	8.0	9.8	11.5	13.2	17	27.5	6.4	8.2	11.4	17.4	26.8	3.2	4.1	5.7	8.7	13.4	
Load Motor Resistance (ohms) 1	(black & black)	Minimum	1.0	4.2	3.0	2.2	1.5													
		Maximum	1.3	5.2	3.6	2.7	1.9													
	Main Winding (black & yellow)	Minimum						1.8	1.0	.68	3.2	2.3	1.8	1.0	.61	13.0	9.2	7.2	4.0	2.5
		Maximum						2.3	1.5	1.0	4.0	3.0	2.2	1.2	.75	16.0	12.0	8.8	4.9	3.1
	Start Winding (red & yellow)	Minimum						5.8	3.5	1.8	--	--	--	--	--	--	--	--	--	--
		Maximum						7.2	4.4	2.2	--	--	--	--	--	--	--	--	--	--

For All 4" Submersible Pumps

(1) For motor without drop cable attached.

NOTE: For operation of 230 volts motors on 208 volts, substitute special relay No. 155031-103 in control box, and use 2 sizes larger cable.

CAUTION: USE OF WIRE SIZES SMALLER THAN DETERMINED ABOVE WILL VOID WARRANTY, since low starting voltage and early failure of the units will result. Larger wire sizes (smaller numbers), may always be used to improve economy of operation. FOR 3Ø MOTORS, standard 3Ø magnetic starter with special extra-quick trip overload relays in all 3 legs is required for positive motor protection. Consult Franklin Electric Service Manual for proper overload relay to use. **WARRANTY IS VOID** where this protection is not used.

BASIC WIRING DIAGRAMS

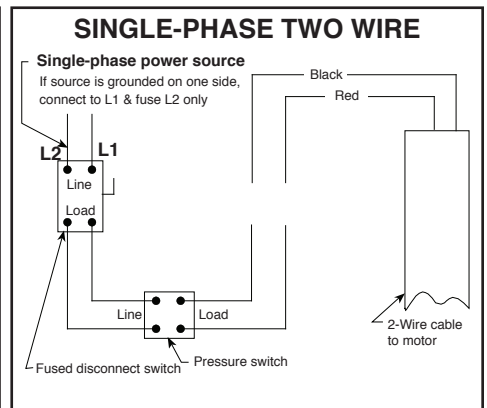
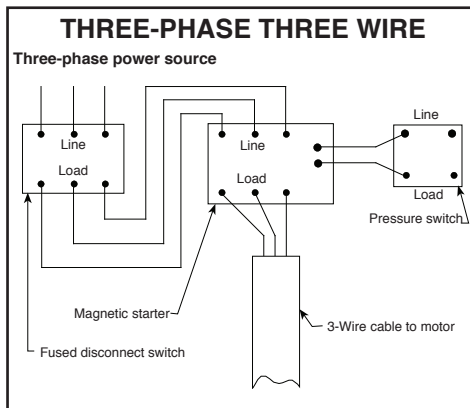
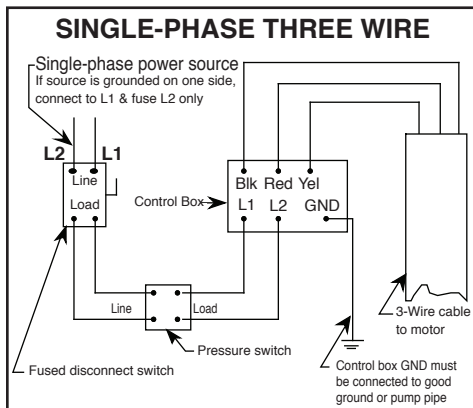

TYPICAL INSTALLATIONS

Two Wire Installation (with contained-air pressure tank)

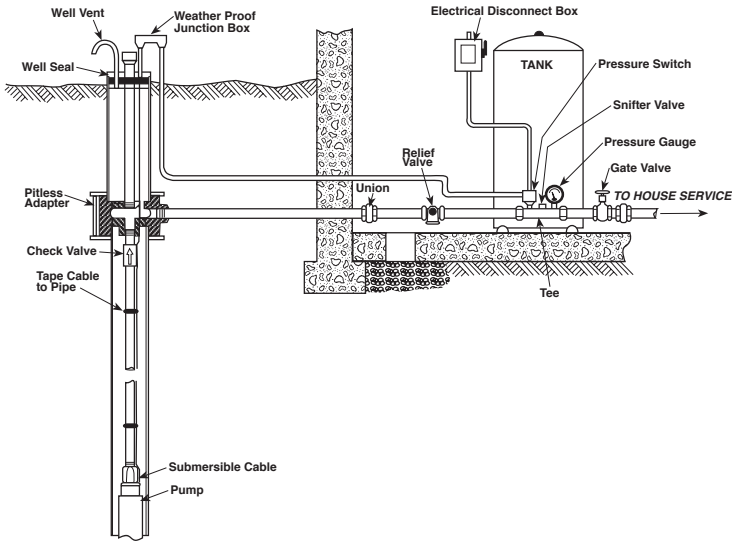

Three Wire Installation (with contained-air pressure tank)

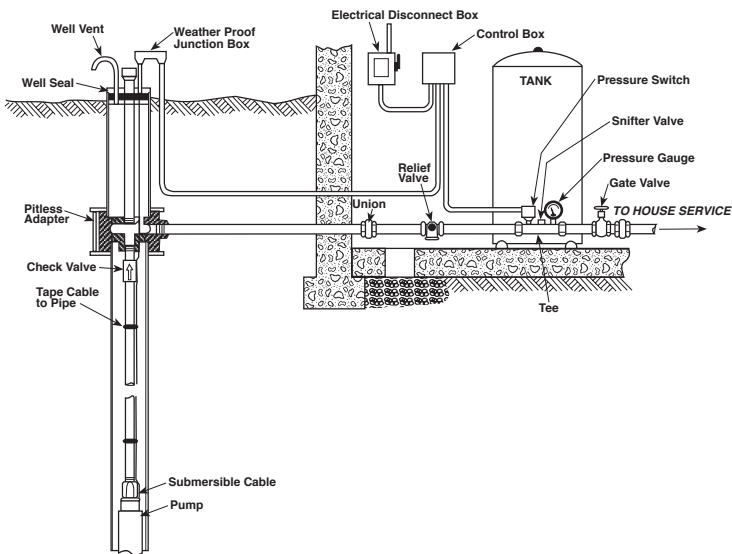

Typical Submersible Installation (well pit)

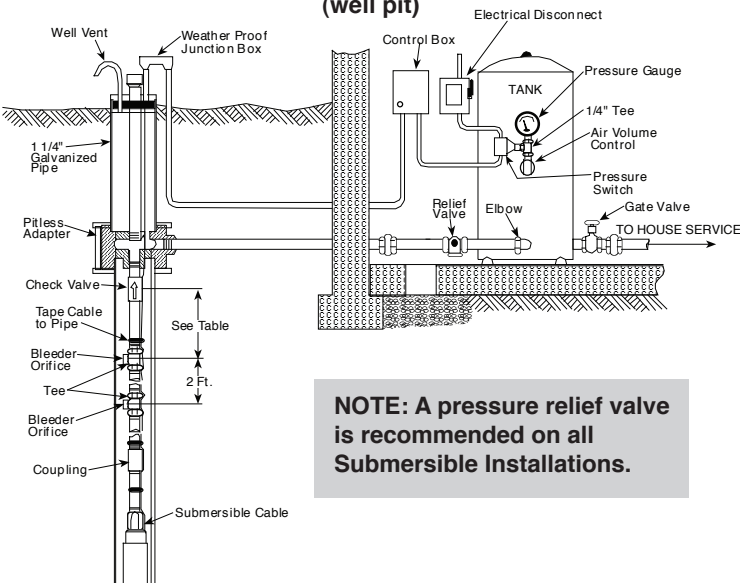

NOTE: A pressure relief valve is recommended on all Submersible Installations.

HYDRAULIC CHECK CHART

CONDITION

1. Motor runs but delivers no water
2. Low delivery
3. Pump does not stop running
4. Pump starts and stops too often
5. Service line discharges milky water

1	2	3	4	5	WHAT TO CHECK
✓					Pump not in water supply
✓					Check valve backwards or stuck shut
✓		✓			Pump air or gas locked
✓	✓	✓			Inlet screen clogged
✓	✓				Pump plugged with deposits from well
✓	✓	✓			Water pumping level lowers
✓	✓				Pump setting in sand or mud
✓					Broken pump shaft or coupling
✓	✓				Drop pipe clogged or broken
✓	✓	✓			Incorrectly selected pump
✓	✓	✓			Worn pump parts
	✓	✓	✓	✓	Leak in drop pipe
		✓			Cut-out of pressure switch too high
		✓	✓		Leak on discharge side of tank
			✓		Tank water-logged
			✓		Tank too small in size
			✓		Switch out of adjustment
			✓		Check valve stuck open
			✓		Bleed-back valve plugged
				✓	Air volume control faulty
				✓	Bleed-back valve set too deep
				✓	Well water naturally gaseous

ELECTRIC CHECK CHART

CONDITION

1. Motor does not start when fused switch is closed
2. Overload protector trips
3. Relay chatters but overload does not trip
4. Fuses blow but overload does not trip
5. Overload trips after pump has run for some time

1	2	3	4	5	WHAT TO CHECK
✓					Power is off
✓					Loose or broken wire
✓		✓			Line fuse is blown
✓	✓	✓			Overload not set
✓	✓				Pressure switch contacts burned or open
✓	✓	✓			Wiring wrong in control box
✓	✓				Crooked well
✓					Low voltage
✓	✓				Loose connection in control box
✓	✓	✓			Wires to control box too small
✓	✓	✓			Amperage too high
	✓	✓	✓	✓	Insufficient power at entrance box
		✓			Cable size to motor too small
		✓	✓		Motor winding faulty
			✓		Motor or cable grounded
			✓		Wrong relay in control box
			✓		Capacitor faulty
			✓		Relay faulty
			✓		Pump running tight
			✓		Locked with sand
			✓		Worn bearing
			✓		Control box in hot location
	✓		✓		Voltage too high
✓	✓				Wrong control box
			✓		Bare wire touching control box
			✓		Line fuses too small